

SPECIFICATION

ROBUR WLD Series Mobile Scissor Lift Table

An extensive range of light and highly versatile work positioners providing an adjustable working height with fast lift and controlled lowering. Available with manual or battery lift options for the safe and efficient handling of a wide variety of loads.

- Capacities: 150, 300, 500, 800, 1000, 1250kg
- Lift heights: 780 to 1900mm
- Foot operated hydraulic pump or battery lift
- Single, double or triple scissor
- Fast lift - controlled lowering
- Adjustable working height
- Overload safety valve
- Castor wheel brake to lock rear wheels
- Strong, durable construction
- Safe, light and easy to move

- Transfer loads at working height
 - Extend machine tool work surface
 - Portable workbench
 - Load/unload vans, shelves etc.
- Options:-

- Aluminium model - 150kg capacity
- Roller top, ball table
- Triple lift to 2900mm
- Painted 'safety' yellow and black
- All models are CE Marked

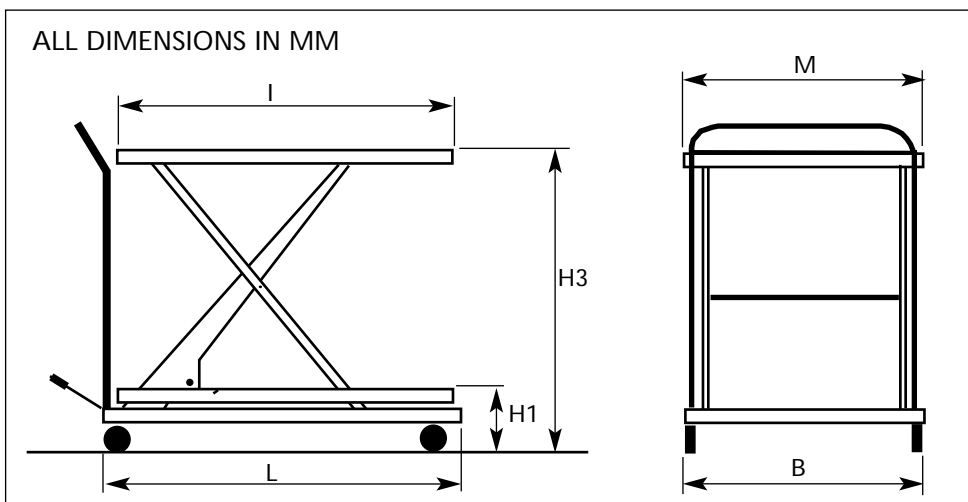

Model (single scissor)		WLD SMI50	WLD SM300	WLD SM500	WLD SM800	WLD SM1250	WLD SB500	WLD SB1250
Maximum capacity (kg)		150	300	500	800	1250	500	1250
Platform length x width (mm)	I x M	760 x 450	840 x 500	1030 x 610	1350 x 840	1350 x 840	1030 x 610	1350 x 840
Overall length x width (mm)	L x B	990 x 450	1130 x 500	1320 x 610	1650 x 860	1650 x 860	1330 x 610	1650 x 860
Lowered platform height (mm)	H1	255	335	340	360	360	340	360
Raised platform height (mm)	H3	780	840	900	1050	1050	900	1050
Battery		-	-	-	-	-	70Ah-12V	70Ah-12V
Charger 240V		-	-	-	-	-	6A	6A

Model (double scissor)		WLD DM125	WLD DM450	WLD DM500	WLD DM800	WLD DB125	WLD DB450	WLD DB500	WLD DB800
Maximum capacity (kg)		125	450	500	800	125	450	500	800
Platform length x width (mm)	I x M	840 x 500	1030 x 610	1350 x 840	1350 x 840	840 x 500	1030 x 610	1350 x 840	1350 x 840
Overall length x width (mm)	L x B	1090 x 500	1350 x 665	1660 x 860	1350 x 860	1130 x 500	1350 x 665	1660 x 860	1350 x 860
Lowered platform height (mm)	H1	430	295	490	490	430	295	490	490
Raised platform height (mm)	H3	1420	1550	1900	1900	1420	1550	1900	1900
Battery		-	-	-	-	70Ah-12V	70Ah-12V	70Ah-12V	70Ah-12V
Charger 240V		-	-	-	-	6A	6A	6A	6A

ROBUR

Stanley Handling Limited

Coldharbour Lane, Harpenden, Herts AL5 4UR
 Tel 01582 767711 (12 Lines) Fax 01582 765994
 E-mail robur@stanleyhandling.co.uk