

SPECIFICATION

ROBUR K9/TE Powered Pallet Truck

An economically priced, value-for-money electric pallet truck with both the strength and durability of many higher capacity models. Low unladen weight means it is an ideal machine for use on mezzanine floors.

- 1500kg capacity
- Ergonomic design
- Butterfly controls in rounded safety handle
- Built-in battery charger
- Electromagnetic braking
- Electronic speed control
- Battery discharge indicator
- Tandem load rollers
- Electric horn
- Operator safety button
- Unladen weight 200kg
- Lateral castoring wheels
- High frequency charger
- Isolating switch
- Painted 'safety' yellow and black
- All models are CE marked

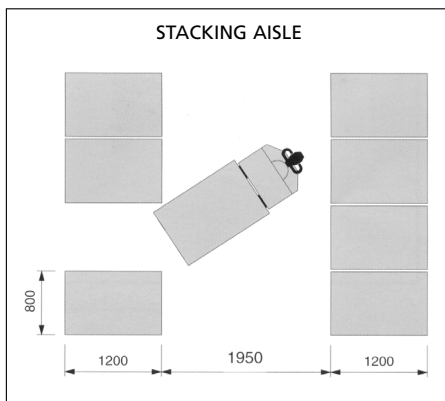
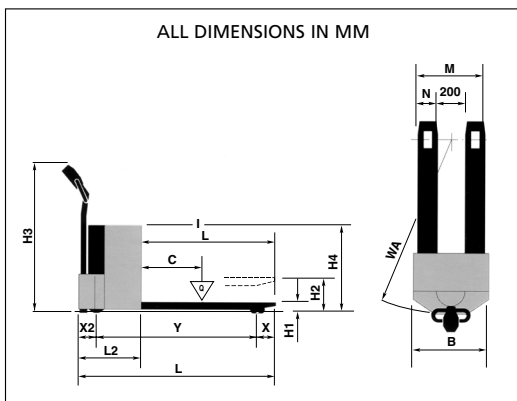

Model	K9/TE
Maximum capacity @ 600mm load centres (kg)	1500
Fork length (mm)	I
Fork width (mm)	M
Overall truck length (mm)	L
Wrap-over forks length x width (mm)	I x M
Lowered fork height (mm)	H1
Raised fork height (mm)	H2
Overall truck height (mm)	H3
Overall truck width (mm)	B
90° aisle - 1000mm load length (mm)	1850
Maximum lift time to full height (sec)	5
Maximum travel speed (km/h)	5
Rubber drive wheel (mm)	250dia x 76
Polyurethane tandem load rollers (mm)	125dia x 40
Battery	90Ah - 24V
Charger	Built-on charger
Weight (kg)	200

ROBUR

Stanley Handling Limited
 Coldharbour Lane, Harpenden, Herts AL5 4UR
 Tel 01582 767711 (12 Lines) Fax 01582 765994
 E-mail robur@stanleyhandling.co.uk
www.stanleyhandling.co.uk