

SPECIFICATION

ROBUR HL High Lift Pallet Truck

This specialist handling aid combines the functions of a pallet truck for general handling and a work positioner for production and loading areas. Designed to prevent backstrain, unnecessary stooping and increase operator welfare and efficiency. Designed for open pallets.

- 1000kg capacity
- Lift heights: 800mm
- Manual and battery lift models
- Lateral stability safety brake
- Controls: up, down, neutral
- Fixed stabilisers at operational height
- 180° steering angle
- 2 stage ram
- For use with non bottom-boarded pallets
- Light and easy to manoeuvre
- Strong, durable construction
- Quick lift
- Ergonomic handle
- Painted 'safety' yellow and black
- All models are CE marked
- Options : 680mm fork width

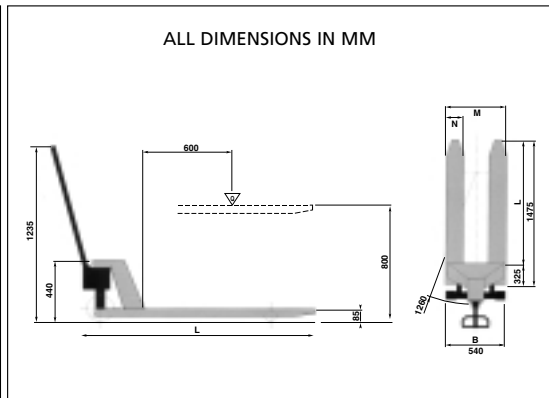
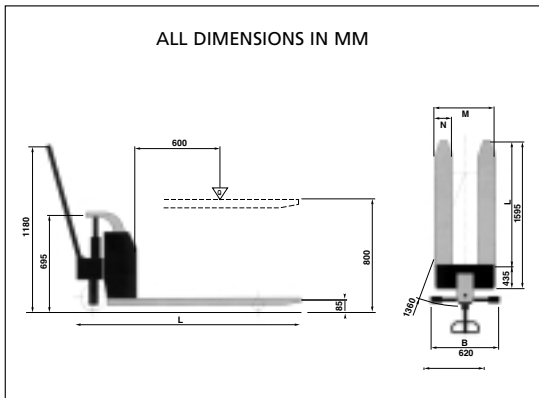

Model		HLH5411	HLH6811	HLB5411	HLB6811
Maximum capacity @ 600mm load centres (kg)		1000	1000	1000	1000
Lift height (mm)	H3	800	800	800	800
Fork length (mm)		1150	1150	1150	1150
Fork width (mm)	M	540	680	540	680
Overall truck length (mm)	L	1505	1505	1650	1650
Lowered fork height (mm)	H1	85	85	85	85
Overall truck width (mm)	B	540	680	540	680
Lift speed per stroke (mm per stroke)		31	31	-	-
Lift speed to maximum height (sec)		-	-	12	12
Nylon front load rollers (mm)		70dia x 50	70dia x 50	70dia x 50	70dia x 50
Rubber steer wheels (mm)		180dia x 50	180dia x 50	180dia x 50	180dia x 50
Weight (kg)		105	110	140	145
Battery		-	-	45Ah 12V	45Ah 12V
Charger		-	-	12V 10A	12V 10A
Optional extras:	Shorter or wider forks, capacities up to 1200kg.				

ROBUR

Stanley Handling Limited

Coldharbour Lane, Harpenden, Herts AL5 4UR
 Tel 01582 767711 (12 Lines) Fax 01582 765994
 E-mail robur@stanleyhandling.co.uk
www.stanleyhandling.co.uk