

SPECIFICATION

ROBUR SBX Powered Stacker

A highly economic powered lift and drive stacker for effortless handling within a wide range of frequent use environments. Excellent manoeuvrability combined with fast lift and lowering provides a cost effective solution for many handling tasks. Suitable for use with Euro and non-bottom boarded pallets.

- Capacity @ 600mm load centres: 1000, 1200kg
 - Lift heights: 1515, 2415, 2915mm
 - Powered lift and drive
 - Electronic speed control
 - Lift speed 0.12 - 0.20m/sec
 - Travel speed up to 5km/hr
 - Electromagnetic braking
 - Clear view mast
 - Load back rest
 - Operator safety button
 - Electric horn
- Equipped with 2 mono block batteries
 - Battery discharge indicator
 - Built-in charger
 - Highly manoeuvrable
 - Strong, durable construction
 - Low noise levels
 - Painted 'safety' yellow and black
 - All models are CE marked
 - Options: Straddles 850 - 1300mm (for bottom-boarded pallets), heavy duty model SBX/S capacities 1000, 1200kg; lift heights 1515, 2415, 2915, 3415mm

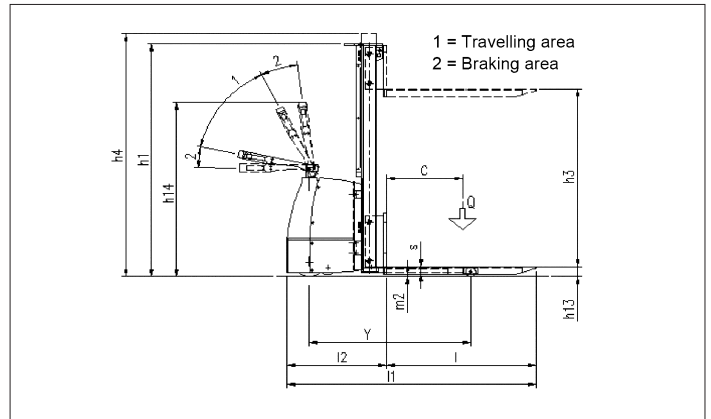
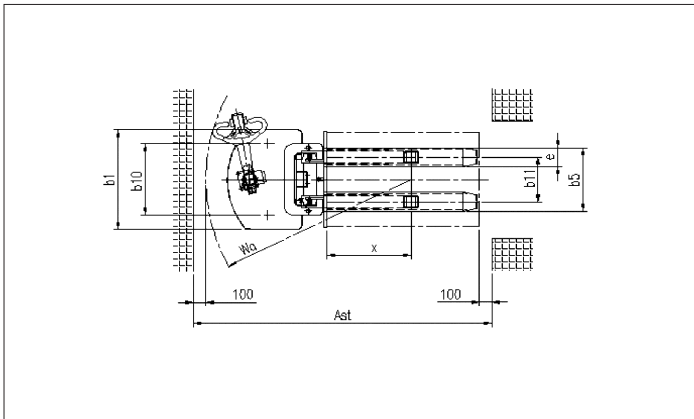

Model		SBX1610	SBX2510	SBX3010	SBX1612	SBX2512	SBX3012
Maximum capacity @ 600mm load centres (kg)		1000	1000	1000	1200	1200	1200
Maximum capacity @ full height (kg)		1000	1000	700	1000	1000	700
Lift height (mm)	H3	1515	2415	2915	1515	2415	2915
Fork length (mm)	l	1180	1180	1180	1180	1180	1180
Fork width (mm)	M	540	540	540	540	540	540
Overall truck length (mm)	L	1910	1910	1910	1910	1910	1910
Lowered mast height (mm)	H1	1985	1750	1995	1985	1750	1995
Lowered fork height (mm)	H2	85	85	85	85	85	85
Overall truck height (mm)	H4	2045	2960	3460	2045	2960	3460
Overall truck width (mm)	B	850	850	850	850	850	850
90° aisle - 1000mm load length (mm)		2270	2270	2270	2270	2270	2270
Lift speed (m/sec)		0.12/0.20	0.12/0.20	0.12/0.20	0.12/0.20	0.12/0.20	0.12/0.20
Maximum travel speed laden/unladen (km/h)		4/5	4/5	4/5	4/5	4/5	4/5
Vulkollen steel wheels (mm)		250x50	250x50	250x50	250x50	250x50	250x50
Front vullkollen load rollers (mm)		80x80	80x80	80x80	80x80	80x80	80x80
Battery		2x90Ah-12V	2x90Ah-12V	2x90Ah-12V	2x90Ah-12V	2x90Ah-12V	2x90Ah-12V
Charger 240v		13A	13A	13A	13A	13A	13A
Weight (kg)		492	522	552	492	522	552
Options:	Straddles 850-1300mm (for bottom boarded pallets), heavy duty model SBX/S capacities 1000, 1200kg; lift heights 1515, 2415, 2915, 3415mm.						

All information is correct at the time of printing. We reserve the right to change specifications without notice.

ROBUR

Stanley Handling Limited

Coldharbour Lane, Harpenden, Herts. AL5 4UR

Tel 01582 767711 Fax 01582 765994

E-mail: sales@stanleyhandling.co.uk web: www.stanleyhandling.co.uk